

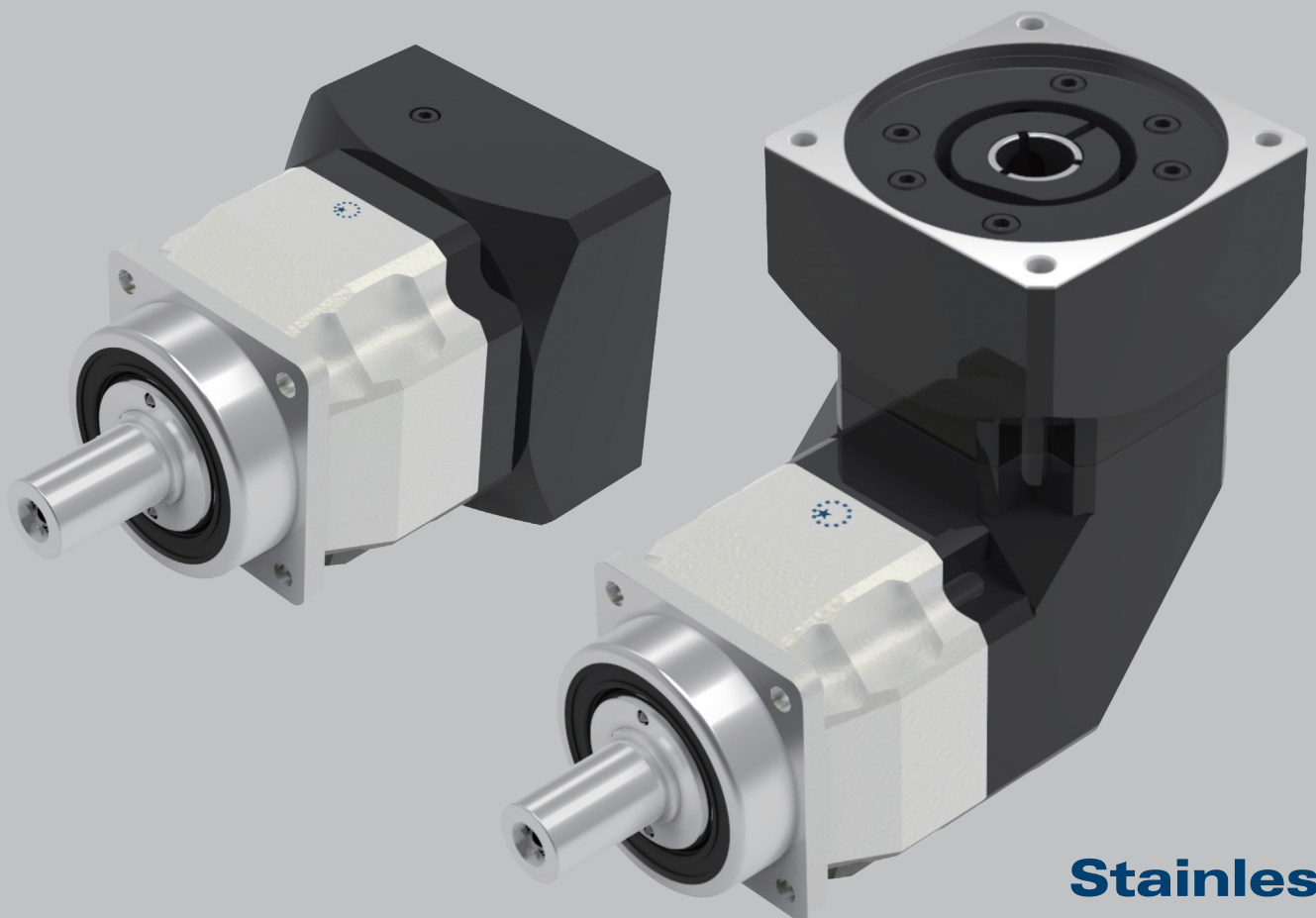

APEX DYNAMICS, INC.

**高精度
行星式减速机
AFX / AFXR 系列**



Stainless

减速机系列-AFX/AFXR

▶ 产品特性

高扭力
最佳化扭力及惯性力矩输出
高精度/低背隙
耐久高精度设计
低噪音
低温升

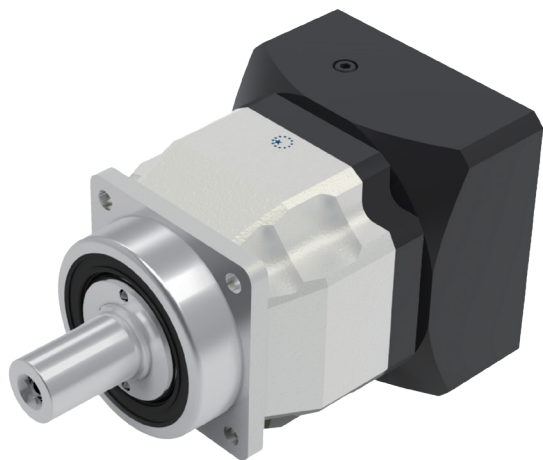

AFX

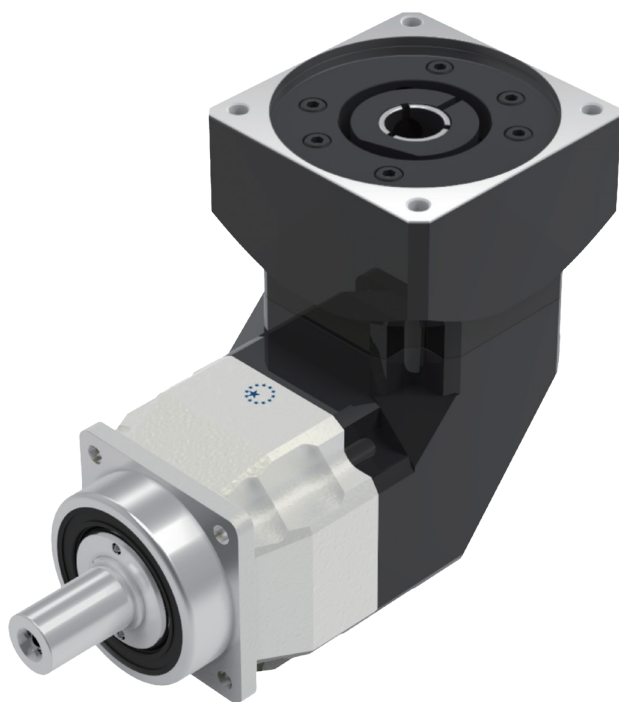

AFXR

AFX 系列产品规格

减速机性能资料

型 号		节数	减速比 ⁽¹⁾	AFX042 ²	AFX060	AFX060A	AFX075	AFX075A	AFX100	AFX100A	AFX140	AFX140A	AFX180	
额定输出力矩 T _{2N}	Nm	1	3	20	55	-	130	-	208	-	342	-	588	
			4	19	50	-	140	-	290	-	542	-	1,050	
			5	22	60	-	160	-	330	-	650	-	1,200	
			6	20	55	-	150	-	310	-	600	-	1,100	
			7	19	50	-	140	-	300	-	550	-	1,100	
			8	17	45	-	120	-	260	-	500	-	1,000	
			9	14	40	-	100	-	230	-	450	-	900	
			10	14	40	-	100	-	230	-	450	-	900	
			2	12	19	50	50	140	140	290	290	542	542	1,050
				15	20	55	55	130	130	208	330	342	650	588
		16		19	50	50	140	140	290	290	542	542	1,050	
		20		19	50	50	140	140	290	330	542	650	1,050	
		25		22	60	60	160	160	330	330	650	650	1,200	
		28		19	50	50	140	140	300	300	550	550	1,100	
		30		20	55	55	150	150	310	310	600	600	1,100	
		32		17	45	45	120	120	260	260	500	500	1,000	
		35		19	50	50	140	140	300	300	550	550	1,100	
		40		17	45	45	120	120	260	260	500	500	1,000	
		45	14	40	40	100	100	230	230	450	450	900		
		50	22	60	60	160	160	330	330	650	650	1,200		
60	20	55	55	150	150	310	310	600	600	1,100				
70	19	50	50	140	140	300	300	550	550	1,100				
80	17	45	45	120	120	260	260	500	500	1,000				
90	14	40	40	100	100	230	230	450	450	900				
100	14	40	40	100	100	230	230	450	450	900				
急停力矩 T _{2NOT} ⁽²⁾	Nm	1,2	3~100	3倍额定输出力矩										
额定输入转速 n _{1N}	rpm	1,2	3~100	5,000	5,000	5,000	4,000	4,000	4,000	4,000	3,000	3,000	3,000	
最大输入转速 n _{1B}	rpm	1,2	3~100	10,000	10,000	10,000	8,000	8,000	8,000	8,000	6,000	6,000	6,000	
超精密背隙 P0	arcmin	1	3~10	-	-	-	≤1	-	≤1	-	≤1	-	≤1	
		2	15~100	-	-	-	-	-	≤3	-	≤3	-	≤3	
精密背隙 P1	arcmin	1	3~10	≤3	≤3	-	≤3	-	≤3	-	≤3	-	≤3	
		2	15~100	≤5	≤5	≤5	≤5	≤5	≤5	≤5	≤5	≤5	≤5	
标准背隙 P2	arcmin	1	3~10	≤5	≤5	-	≤5	-	≤5	-	≤5	-	≤5	
		2	15~100	≤7	≤7	≤7	≤7	≤7	≤7	≤7	≤7	≤7	≤7	
扭转刚性	Nm/arcmin	1,2	3~100	3	7	7	14	14	25	25	50	50	145	
容许径向力 F _{2rB} ⁽³⁾	N	1,2	3~100	610	2,900	2,900	4,500	4,500	7,800	9,200	9,450	14,000	15,600	
容许轴向力 F _{2aB} ⁽³⁾	N	1,2	3~100	320	1,450	1,450	2,250	2,250	3,900	5,820	4,725	11,400	7,800	
效率 η	%	1	3~10	≥97%										
		2	15~100	≥94%										
重量	kg	1	3~10	0.6	1.7	1.5	3.5	4.1	7.4	11.3	15.8	22.5	32.7	
		2	15~100	0.8	2	2	4	5.5	9	10.6	19.1	20.2	37.6	
使用温度	°C	1,2	3~100	-10°C~+90°C										
润滑		1,2	3~100	合成润滑油脂										
防护等级		1,2	3~100	IP65										
安装方向		1,2	3~100	任意方向										
噪音 ⁽⁴⁾	dB	1,2	3~100	≤56	≤58	≤60	≤60	≤63	≤63	≤65	≤65	≤67	≤67	

(1) 减速比 (i=N_{in} / N_{out})

(2) 最大输出力矩 T_{2B} = 60% of T_{2NOT}

(3) 输出转速100RPM时候, 并作用于输出轴中心位置

(4) 此数据在无负载状态, 以3000转量测10比(单节)或100比(双节)减速机取得。
当速比更低或每分钟转速更高时, 噪音等级将会高3到5分贝。

(5) 不建议连续运转使用。

减速机转动惯量

型 号		节数	减速比 ⁽¹⁾	AFX042	AFX060	AFX060A	AFX075	AFX075A	AFX100	AFX100A	AFX140	AFX140A	AFX180	
转动惯量 J ₁	kg · cm ²	1	3	0.03	0.16	—	0.61	—	3.25	—	9.21	—	28.98	
			4	0.03	0.14	—	0.48	—	2.74	—	7.54	—	23.67	
			5	0.03	0.13	—	0.47	—	2.71	—	7.42	—	23.29	
			6	0.03	0.13	—	0.45	—	2.65	—	7.25	—	22.75	
			7	0.03	0.13	—	0.45	—	2.62	—	7.14	—	22.48	
			8	0.03	0.13	—	0.44	—	2.58	—	7.07	—	22.59	
			9	0.03	0.13	—	0.44	—	2.57	—	7.04	—	22.53	
			10	0.03	0.13	—	0.44	—	2.57	—	7.03	—	22.51	
			2	12	0.03	0.03	0.16	0.16	0.61	0.61	3.25	3.25	9.21	9.21
				15	0.03	0.03	0.13	0.13	0.47	0.47	3.25	2.71	9.21	7.42
		16		0.03	0.03	0.14	0.14	0.48	0.48	2.74	2.74	7.54	7.54	
		20		0.03	0.03	0.13	0.13	0.47	0.47	2.74	2.71	7.54	7.42	
		25		0.03	0.03	0.13	0.13	0.47	0.47	2.71	2.71	7.42	7.42	
		28		0.03	0.03	0.14	0.14	0.48	0.48	2.74	2.74	7.54	7.54	
		30		0.03	0.03	0.13	0.13	0.47	0.47	2.71	2.71	7.42	7.42	
		32		0.03	0.03	0.14	0.14	0.48	0.48	2.74	2.74	7.54	7.54	
		35		0.03	0.03	0.13	0.13	0.47	0.47	2.71	2.71	7.42	7.42	
		40		0.03	0.03	0.13	0.13	0.47	0.47	2.71	2.71	7.42	7.42	
		45	0.03	0.03	0.13	0.13	0.47	0.47	2.71	2.71	7.42	7.42		
		50	0.03	0.03	0.13	0.13	0.44	0.44	2.57	2.57	7.03	7.03		
60	0.03	0.03	0.13	0.13	0.44	0.44	2.57	2.57	7.03	7.03				
70	0.03	0.03	0.13	0.13	0.44	0.44	2.57	2.57	7.03	7.03				
80	0.03	0.03	0.13	0.13	0.44	0.44	2.57	2.57	7.03	7.03				
90	0.03	0.03	0.13	0.13	0.44	0.44	2.57	2.57	7.03	7.03				
100	0.03	0.03	0.13	0.13	0.44	0.44	2.57	2.57	7.03	7.03				

AFX 系列尺寸 (单节, 减速比 i=3~10)

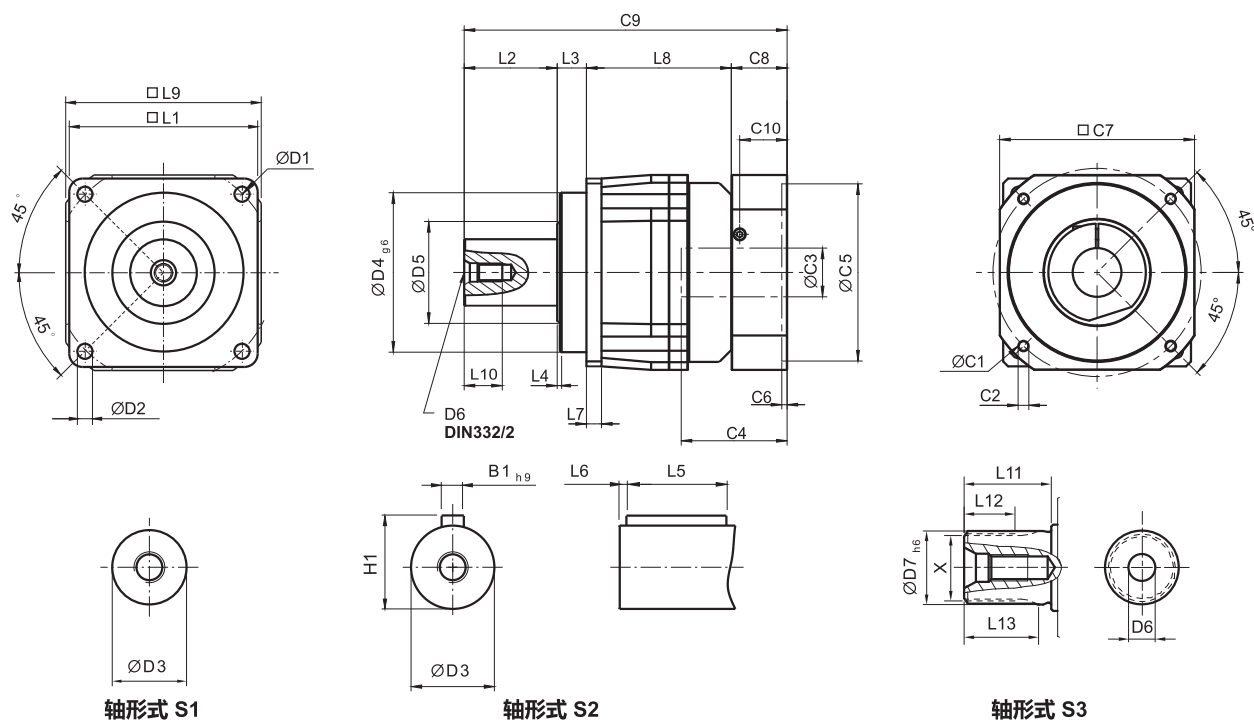

[单位: mm]

尺寸	AFX042	AFX060	AFX075	AFX100	AFX140	AFX180
D1	50	68	85	120	165	215
D2	3.4	5.5	6.8	9	11	13
D3	12 _{js}	16 _{h6}	22 _{h6}	32 _{h6}	40 _{h6}	55 _{h6}
D4 g6	35	60	70	90	130	160
D5	22	21	30	40	75	95
D6	M4 x 0.7P	M5 x 0.8P	M8 x 1.25P	M12 x 1.75P	M16 x 2P	M20 x 2.5P
D7 h6	-	16	22	32	40	55
L1	42	62	76	105	142	180
L2	19.5	28.5	36.5	58	82	82
L3	6.5	20	19.5	30	30	30
L4	1	1.5	1.5	2	3	3
L5	14	25	32	40	63	70
L6	2	2	3	5	5	6
L7	4	6	7	10	12	15
L8	31	62	84	103.5	132	180.5
L9	42	70	90	115	142	180
L10	10	12.5	19	28	36	42
L11	-	26	26	26	40	41.5
L12	-	15	15	15	20	21.5
L13	-	21	22.5	23	33.5	33.5
C1 ¹	46	70	100	130	165	215
C2 ¹	M4 x 0.7P	M5 x 0.8P	M6 x 1P	M8 x 1.25P	M10 x 1.5P	M12 x 1.75P
C3 ¹	≤11 / ≤12 ²	≤14 / ≤16 ²	≤19 / ≤24	≤32	≤38	≤48
C4 ¹	25	34	40	50	60	85
C5 ¹	30	50	80	110	130	180
C6 ¹	3.5	8	4	5	6	6
C7 ¹	42	60	90	115	142	190
C8 ¹	29.5	19	17	19.5	22.5	29
C9 ¹	86.5	129.5	157	211	266.5	321.5
C10 ¹	8.75	13.5	10.75	13	15	20.75
B1 h9	4	5	6	10	12	16
H1	13.5	18	24.5	35	43	59
X DIN5480	-	W16x0.8x 30x18x6m	W22x1.25x 30x16x6m	W32x1.25x 30x24x6m	W40x2x 30x18x6m	W55x2x 30x26x6m

1. C1~C10是公制标准马达连接板之尺寸, 请网上点选“减速机选用”找出正确之尺寸。

2. AFX042 5,10减速比提供C3≤12可选; AFX060 5,10减速比提供C3≤16可选。

AFX 系列尺寸 (双节, 减速比 $i=15\sim 100$)

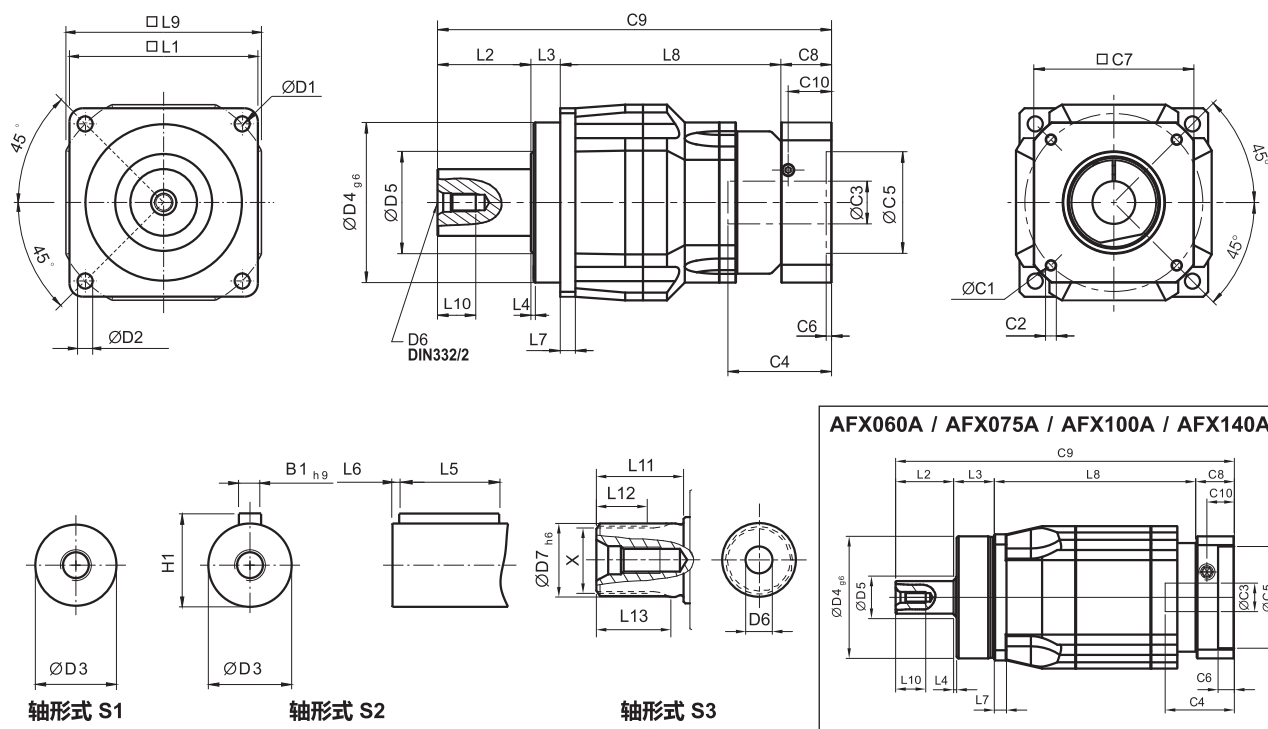

[单位: mm]

尺寸	AFX042	AFX060	AFX060A	AFX075	AFX075A	AFX100	AFX100A	AFX140	AFX140A	AFX180
D1	50	68		85		120		165		215
D2	3.4	5.5		6.8		9		11		13
D3	12 _{j6}	16 _{h6}		22 _{h6}		32 _{h6}		40 _{h6}		55 _{h6}
D4 g6	35	60		70		90		130		160
D5	22	21		30		40		75		95
D6	M4x0.7P	M5x0.8P		M8x1.25P		M12x1.75P		M16x2P		M20x2.5P
D7 h6	-	16		22		32		40		55
L1	42	62		76		105		142		180
L2	19.5	28.5		36.5		58		82		82
L3	6.5	20		19.5		30		30		30
L4	1	1.5		1.5		2		3		3
L5	14	25		32		40		63		70
L6	2	2		3		5		5		6
L7	4	6		7		10		12		15
L8	58.5	73	99	117	132	145	164.5	188.5	203.5	236
L9	42	70		90		115		142		180
L10	10	12.5		19		28		36		42
L11	-	26		26		26		40		41.5
L12	-	15		15		15		20		21.5
L13	-	21		22.5		23		33.5		33.5
C1 ³	46	46	70	70	100	100	130	130	165	165
C2 ³	M4x0.7P	M4x0.7P	M5x0.8P	M5x0.8P	M6x1P	M6x1P	M8x1.25P	M8x1.25P	M10x1.5P	M10x1.5P
C3 ³	≤11/≤12	≤11/≤12	≤14/≤16	≤14/≤15.875/≤16	≤19/≤24	≤19/≤24	≤32	≤32	≤38	≤38
C4 ³	25	25	34	34	40	40	50	50	60	60
C5 ³	30	30	50	50	80	80	110	110	130	130
C6 ³	3.5	3.5	8	8	4	4	5	5	6	6
C7 ³	42	42	60	60	90	90	115	115	142	142
C8 ³	29.5	29.5	19	19	17	17	19.5	19.5	22.5	22.5
C9 ³	114	151	166.5	192	205	250	272	320	338	370.5
C10 ³	8.75	8.75	13.5	13.5	10.75	10.75	13	13	15	15
B1 h9	4	5		6		10		12		16
H1	13.5	18		24.5		35		43		59
X DIN5480	-	W16x0.8x 30x18x6m		W22x1.25x 30x16x6m		W32x1.25x 30x24x6m		W40x2x 30x18x6m		W55x2x 30x26x6m

3. C1~C10是公制标准马达连接板之尺寸, 请上网点选“减速机选用”找出正确之尺寸。

AFXR 系列产品规格

减速机性能资料

型 号		节数	减速比 ⁽¹⁾	AFXR042	AFXR060	AFXR060A	AFXR075	AFXR075A	AFXR100	AFXR100A	AFXR140	AFXR140A	AFXR180	
额定输出力矩 T _{2N}	Nm	1	3	9	36	-	90	-	195	-	342	-	588	
			4	12	48	-	120	-	260	-	520	-	1,040	
			5	15	60	-	150	-	325	-	650	-	1,200	
			6	18	55	-	150	-	310	-	600	-	1,100	
			7	19	50	-	140	-	300	-	550	-	1,100	
			8	17	45	-	120	-	260	-	500	-	1,000	
			9	14	40	-	100	-	230	-	450	-	900	
			10	14	60	-	150	-	325	-	450	-	1,200	
			12	-	55	-	150	-	310	-	600	-	1,100	
			14	-	42	-	140	-	300	-	550	-	1,100	
			16	-	45	-	120	-	260	-	500	-	1,000	
		20	-	40	-	100	-	230	-	450	-	900		
		2	12	12	-	-	-	-	-	-	-	-	-	-
			15	14	-	-	-	-	-	-	-	-	-	-
			16	15	-	-	-	-	-	-	-	-	-	-
			20	14	-	-	-	-	-	-	-	-	-	-
			25	15	60	60	150	150	325	325	650	650	1,200	
			28	19	50	50	140	140	300	300	550	550	1,100	
			30	20	55	55	150	150	310	310	600	600	1,100	
			32	17	45	45	120	120	260	260	500	500	1,000	
			35	19	50	50	140	140	300	300	550	550	1,100	
			40	17	45	45	120	120	260	260	500	500	1,100	
			45	14	40	40	100	100	230	230	450	450	900	
			50	14	60	60	150	150	325	325	650	650	1,200	
			60	20	55	55	150	150	310	310	600	600	1,100	
			70	19	50	50	140	140	300	300	550	550	1,100	
			80	17	45	45	120	120	260	260	500	500	1,000	
			90	14	40	40	100	100	230	230	450	450	900	
			100	14	40	60	100	150	230	325	450	650	900	
			120	-	-	55	150	150	310	310	600	600	1,100	
			140	-	-	50	140	140	300	300	550	550	1,100	
		160	-	-	45	120	120	260	260	550	550	1,000		
180	-	-	40	100	100	230	230	450	450	900				
200	-	-	40	100	100	230	230	450	450	900				
急停力矩 T _{2NOT} ⁽²⁾	Nm	1,2	3~200	3 倍额定输出力矩										
额定输入转速 n _{1N}	rpm	1,2	3~200	5,000	5,000	5,000	4,000	4,000	4,000	4,000	3,000	3,000	3,000	
最大输入转速 n _{1B}	rpm	1,2	3~200	10,000	10,000	10,000	8,000	8,000	8,000	8,000	6,000	6,000	6,000	
超精密背隙 P0	arcmin	1	3~20	-	-	-	≤2	-	≤2	-	≤2	-	≤2	
		2	25~200	-	-	-	≤4	≤4	≤4	≤4	≤4	≤4	≤4	
精密背隙 P1	arcmin	1	3~20	≤4	≤4	-	≤4	-	≤4	-	≤4	-	≤4	
		2	25~200	≤7	≤7	≤7	≤7	≤7	≤7	≤7	≤7	≤7	≤7	
标准背隙 P2	arcmin	1	3~20	≤6	≤6	-	≤6	-	≤6	-	≤6	-	≤6	
		2	25~200	≤9	≤9	≤9	≤9	≤9	≤9	≤9	≤9	≤9	≤9	
扭转刚性	Nm/arcmin	1,2	3~200	3	7	7	14	14	25	25	50	50	145	
容许径向力 F _{2rB} ⁽³⁾	N	1,2	3~200	610	2,900	1,400	4,500	4,100	7,800	9,200	9,450	14,000	15,600	
容许轴向力 F _{2aB} ⁽³⁾	N	1,2	3~200	320	1,450	1,100	2,250	3,700	3,900	5,800	4,725	11,400	7,800	
效率 η	%	1	3~20	≥95%										
		2	25~200	≥92%										
重量	kg	1	3~20	0.9	2.7	3.7	6.1	7.9	12.2	16	25.3	32	50.2	
		2	25~200	1.2	2.4	2.8	4.8	8	11.6	15.1	24	29.2	47.4	
使用温度	°C	1,2	3~200	-10°C~+90°C										
润滑		1,2	3~200	合成润滑油脂										
防护等级		1,2	3~200	IP65										
安装方向		1,2	3~200	任意方向										
噪音 ⁽⁴⁾	dB	1,2	3~200	≤61	≤63	≤65	≤65	≤68	≤68	≤70	≤70	≤72	≤72	

(1) 减速比 (i=N_{in} / N_{out})

(2) 最大输出力矩 T_{2B} = 60% of T_{2NOT}

(3) 输出转速100RPM时候, 并作用于输出轴中心位置

(4) 此数据在无负载状态, 以3000转量测10比(单节)或100比(双节)减速机取得。

当速比更低或每分钟转速更高时, 噪音等级将会高3到5分贝。

(5) 不建议连续运转使用。

减速机转动惯量

型 号		节数	减速比 ⁽¹⁾	AFXR042	AFXR060	AFXR060A	AFXR075	AFXR075A	AFXR100	AFXR100A	AFXR140	AFXR140A	AFXR180	
转动惯量 J ₁	kg · cm ²	1	3~10	0.09	0.35	—	2.25	—	6.84	—	23.4	—	68.9	
			12~20	—	0.07	—	1.87	—	6.25	—	21.8	—	65.6	
		2	12~20											
			15	0.09	—	—	—	—	—	—	—	—	—	—
			20	0.09	—	—	—	—	—	—	—	—	—	—
			25~100	0.09	0.09	0.35	0.35	2.25	2.25	6.84	6.84	23.4	23.4	
	120~200	—	—	0.07	0.31	1.87	1.87	6.25	6.25	21.8	21.8			

AFXR 系列尺寸 (单节, 减速比 i=3~20)

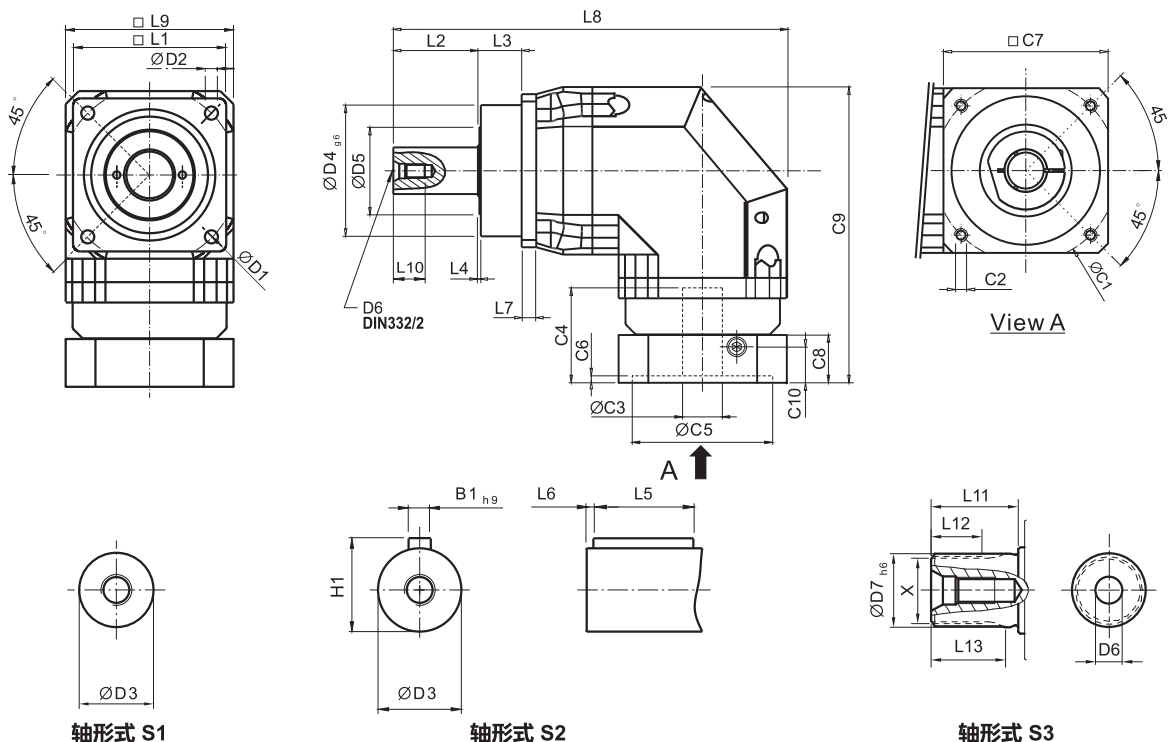

轴形式 S1

轴形式 S2

轴形式 S3

[单位: mm]

尺寸	AFXR042	AFXR060	AFXR075	AFXR100	AFXR140	AFXR180
D1	50	68	85	120	165	215
D2	3.4	5.5	6.8	9	11	13
D3	12 _{js}	16 _{h6}	22 _{h6}	32 _{h6}	40 _{h6}	55 _{h6}
D4 g6	35	60	70	90	130	160
D5	22	21	30	40	75	95
D6	M4 x 0.7P	M5 x 0.8P	M8 x 1.25P	M12 x 1.75P	M16 x 2P	M20 x 2.5P
D7 h6	-	16	22	32	40	55
L1	42	62	76	105	142	180
L2	19.5	28.5	36.5	58	82	82
L3	6.5	20	19.5	30	30	30
L4	1	1.5	1.5	2	3	3
L5	14	25	32	40	63	70
L6	2	2	3	5	5	6
L7	4	6	7	10	12	15
L8	111.5	171.5	216.5	283.5	360.5	427.5
L9	42	70	90	115	142	180
L10	10	12.5	19	28	36	42
L11	-	26	26	26	40	41.5
L12	-	15	15	15	20	21.5
L13	-	21	22.5	23	33.5	33.5
C1'	46	70	100	130	165	215
C2'	M4 x 0.7P	M5 x 0.8P	M6 x 1P	M8 x 1.25P	M10 x 1.5P	M12 x 1.75P
C3'	≤11 / ≤12	≤14 / ≤16	≤19 / ≤24	≤32	≤38	≤48
C4'	25	34	40	50	60	85
C5'	30	50	80	110	130	180
C6'	3.5	8	4	5	6	6
C7'	42	60	90	115	142	190
C8'	29.5	19	17	19.5	22.5	29
C9'	90.5	116.5	152.5	191.5	235.5	303.5
C10'	8.75	13.5	10.75	13	15	20.75
B1 h9	4	5	6	10	12	16
H1	13.5	18	24.5	35	43	59
X DIN5480	-	W16x0.8x 30x18x6m	W22x1.25x 30x16x6m	W32x1.25x 30x24x6m	W40x2x 30x18x6m	W55x2x 30x26x6m

1. C1-C10是公制标准马达连接板之尺寸, 请网上点选“减速机选用”找出正确之尺寸。

AFXR 系列尺寸 (双节, 减速比 $i=15\sim 200$)

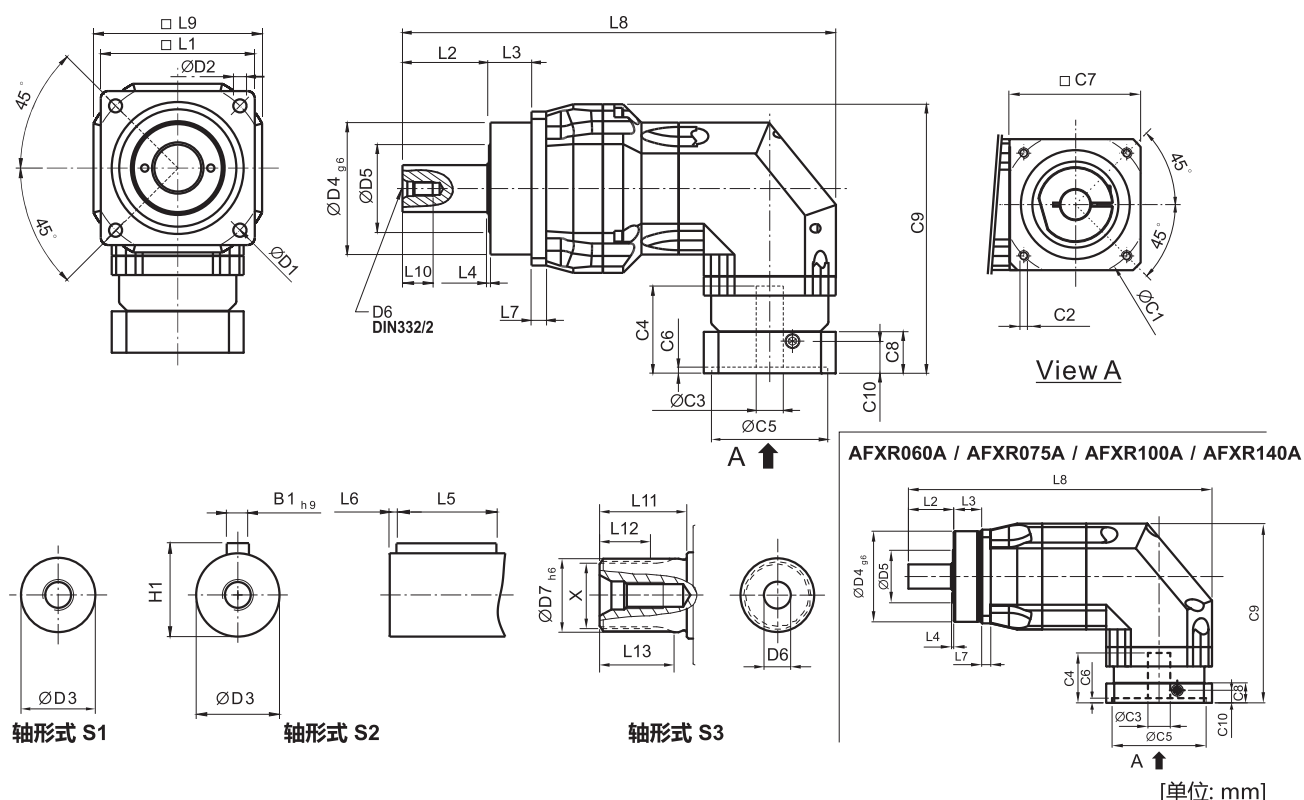

[单位: mm]

尺寸	AFXR042	AFXR060	AFXR060A	AFXR075	AFXR075A	AFXR100	AFXR100A	AFXR140	AFXR140A	AFXR180
D1	50	68		85		120		165		215
D2	3.4	5.5		6.8		9		11		13
D3	12 _{j6}	16 _{h6}		22 _{h6}		32 _{h6}		40 _{h6}		55 _{h6}
D4 _{g6}	35	60		70		90		130		160
D5	22	21		30		40		75		95
D6	M4x0.7P	M5x0.8P		M8x1.25P		M12x1.75P		M16x2P		M20x2.5P
D7 _{h6}	-	16		22		32		40		55
L1	42	62		76		105		142		180
L2	19.5	28.5		36.5		58		82		82
L3	6.5	20		19.5		30		30		30
L4	1	1.5		1.5		2		3		3
L5	14	25		32		40		63		70
L6	2	2		3		5		5		6
L7	4	6		7		10		12		15
L8	139	176	208.5	220	264.5	309.5	344.5	392.5	432	464.5
L9	42	70		90		115		142		180
L10	10	12.5		19		28		36		42
L11	-	26		26		26		40		41.5
L12	-	15		15		15		20		21.5
L13	-	21		22.5		23		33.5		33.5
C1 ²	46	46	70	70	100	100	130	130	165	165
C2 ²	M4x0.7P	M4x0.7P	M5x0.8P	M5x0.8P	M6x1P	M6x1P	M8x1.25P	M8x1.25P	M10x1.5P	M10x1.5P
C3 ²	≤11 / ≤12	≤11 / ≤12	≤14 / ≤16	≤14 / ≤15.875 / ≤16	≤19 / ≤24	≤19 / ≤24	≤32	≤32	≤38	≤38
C4 ²	25	25	34	34	40	40	50	50	60	60
C5 ²	30	30	50	50	80	80	110	110	130	130
C6 ²	3.5	3.5	8	8	4	4	5	5	6	6
C7 ²	42	42	60	60	90	90	115	115	142	142
C8 ²	29.5	29.5	19	19	17	17	19.5	19.5	22.5	22.5
C9 ²	90.5	104.5	116.5	126.5	152.5	165	191.5	205	235.5	254.5
C10 ²	8.75	8.75	13.5	13.5	10.75	10.75	13	13	15	15
B1 _{h9}	4	5		6		10		12		16
H1	13.5	18		24.5		35		43		59
X DIN5480	-	W16x0.8x 30x18x6m		W22x1.25x 30x16x6m		W32x1.25x 30x24x6m		W40x2x 30x18x6m		W55x2x 30x26x6m

2. C1~C10是公制标准马达连接板之尺寸, 请网上点选“减速机选用”找出正确之尺寸。

减速机的选用

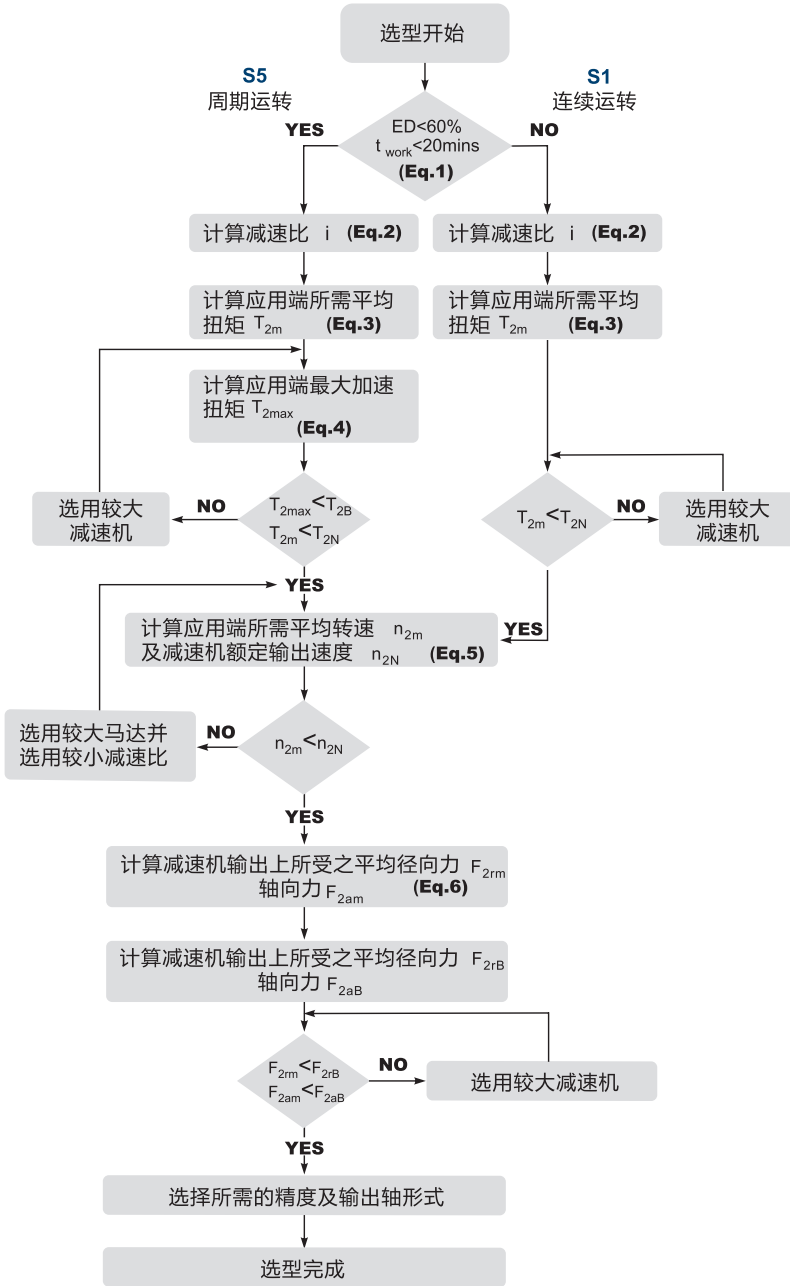

S5 周期运转之建议事项

一般的应用惯量须符合以下公式

$$\frac{J_L}{i^2} \leq 4 \times J_m$$

最适当的应用惯量须符合以下公式

$$\frac{J_L}{i^2} \cong J_m$$

J_L 负载惯性

J_m 马达惯性

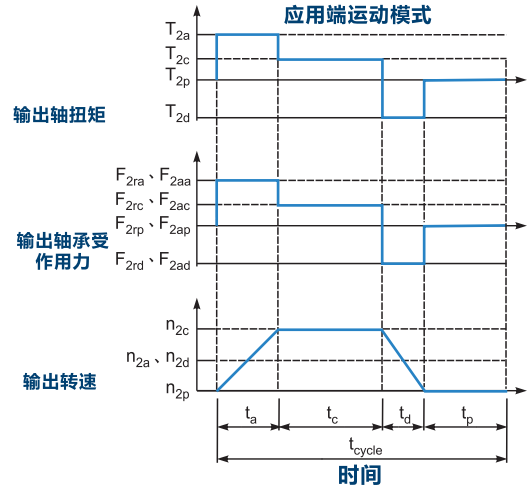

$$1. ED = \frac{t_a + t_c + t_d}{t_{cycle}} \times 100\%, t_{work} = t_a + t_c + t_d$$

下标说明: a. 加速 c. 等速
d. 减速 p. 停止

(Eq.1)

$$2. i \cong \frac{n_m}{n_{work}}$$

n_m 马达输出速度
 n_{work} 实际应用速度

(Eq.2)

$$3. T_{2m} = 3 \sqrt{\frac{n_{2a} \times t_a \times T_{2a}^3 + n_{2c} \times t_c \times T_{2c}^3 + n_{2d} \times t_d \times T_{2d}^3}{n_{2a} \times t_a + n_{2c} \times t_c + n_{2d} \times t_d}}$$

(Eq.3)

$$4. T_{2max} = T_{mB} \times i \times K_s \times \eta$$

K_s 负载系数

K_s	周期次数 / 小时
1.0	0 ~ 1,000
1.1	1,000 ~ 1,500
1.3	1,500 ~ 2,000
1.6	2,000 ~ 3,000
1.8	3,000 ~ 5,000
2.0	5,000 ~ 9,000
2.05	9,000 ~ 10,000
not recommended	above 10,000

T_{mB} 马达最大输出扭矩

η 减速机运转效率

(Eq.4)

$$5. n_{2a} = n_{2d} = \frac{1}{2} \times n_{2c}$$

$$n_{2m} = \frac{n_{2a} \times t_a + n_{2c} \times t_c + n_{2d} \times t_d}{t_a + t_c + t_d}$$

$n_{2N} = \frac{n_{1N}}{i}$ (Eq.5)

$$6. F_{2rm} = 3 \sqrt{\frac{n_{2a} \times t_a \times F_{2ra}^3 + n_{2c} \times t_c \times F_{2rc}^3 + n_{2d} \times t_d \times F_{2rd}^3}{n_{2a} \times t_a + n_{2c} \times t_c + n_{2d} \times t_d}}$$

$$F_{2am} = 3 \sqrt{\frac{n_{2a} \times t_a \times F_{2aa}^3 + n_{2c} \times t_c \times F_{2ac}^3 + n_{2d} \times t_d \times F_{2ad}^3}{n_{2a} \times t_a + n_{2c} \times t_c + n_{2d} \times t_d}}$$

(Eq.6)

减速机输出轴之容许径向力及轴向力

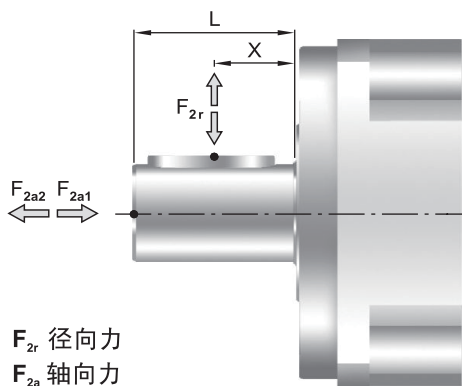

减速机输出轴所能承受之最大径向力及轴向力，端视内部支撑轴承之设计，台湾广用减速机采用大尺寸的轴承及较大跨距的设计，其能承受更大的径向及轴向负荷。

F_{2r} 径向力
 F_{2a} 轴向力

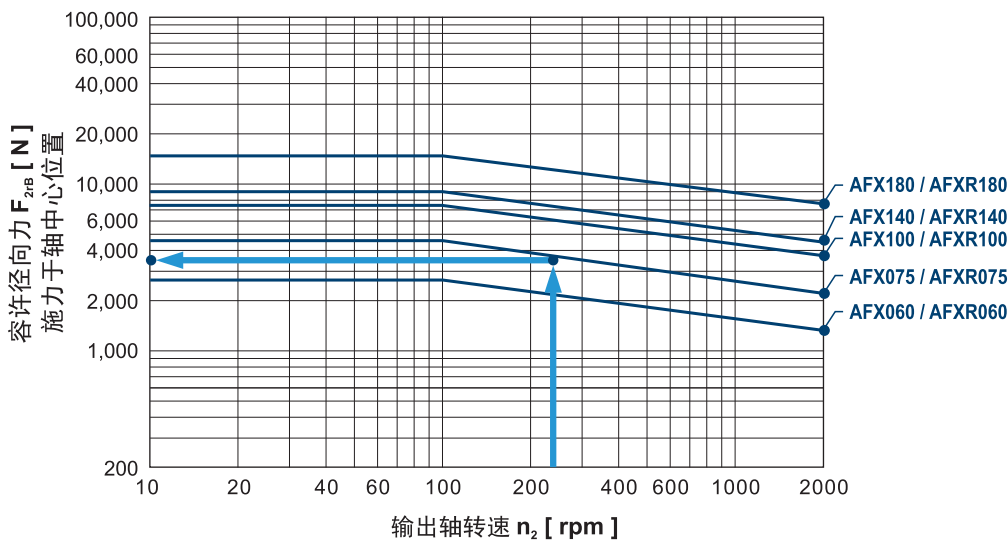

当径向力 F_{2r} 施力于轴中心位置即 $X=1/2 \times L$ 时，不同规格之减速机在不同输出转速运用下，使用寿命为 20,000hr* 时，所能承受之容许径向力 F_{2rB} ，请参照左图。

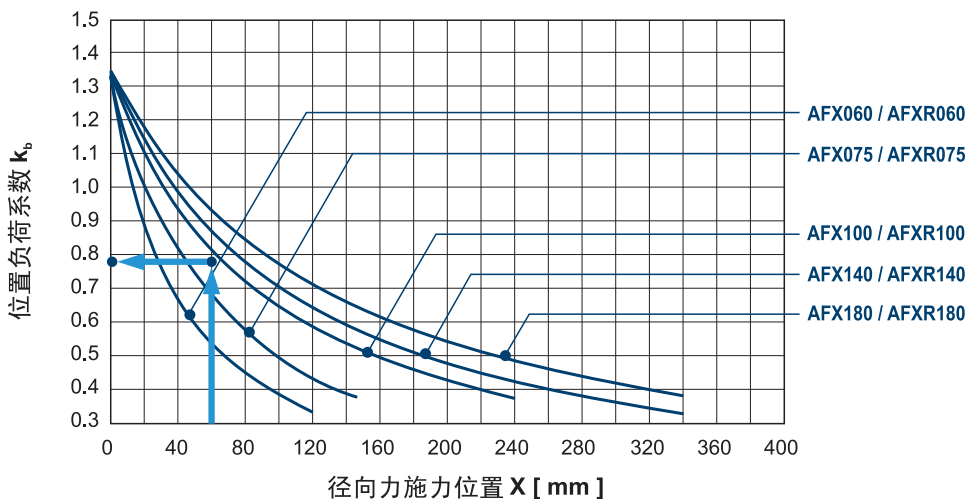

当径向力 F_{2r} 施力不在轴中心位置时，越靠近减速机即 $X < 1/2 \times L$ ，所能承受之容许径向力变大，越远离减速机即 $X > 1/2 \times L$ 时，所能承受之容许径向力则变小，藉由左图，依减速机规格及径向力施力位置 X ，查出位置负荷系数 K_0 。

Note

Note



APEX DYNAMICS, INC.
上海精锐广用动力科技有限公司

上海市青浦工业园区竹盈路128号
No.128 Zhuying Road, Qingpu Industry Zone, Shanghai
TEL:86-21-69220577 FAX:86-21-69220571
<http://www.apexdyna.cn>
E-mail: sales@apexdyna.cn

服务热线 : 86-21-69220585

APEX-2019-06-AFX/AFXR SERIES-1.0C-1.0V



公司网址



公司微信